

# *Application*

## Sawyer Hill EcoVillage Affordable Cohousing

Mosaic and Camelot Neighborhoods  
Berlin, MA

**Sales Prices: 1BRs are \$138,000, 2BRs are \$154,470, 3BRs are \$173,000**  
Sale Prices do not change based on an applicant's income.

**Maximum Household Income Limits:** \$46,300 (1 person), \$52,950 (2 people), \$59,550 (3 people), and \$66,150 (4 people), \$71,450 (5 people), \$76,750 (6 people)

**There are no MINIMUM Household Income Requirements but households must submit mortgage pre-approvals.**

**Maximum Household Asset Limits:** \$75,000

Homes are being sold on a first-come, first-served basis to eligible households. Please read the Information Packet for more details.

### **Directions:**

This application consists of three sections:

- Section 1: The Program Application
- Section 2: The Required Forms and Documentation Workbook
- Section 3: Additional Forms (*if applicable*)

The first two sections must be filled out entirely in order for your application to be processed. If a question does not apply to you, write "N/A" or cross it out. LEAVE NOTHING BLANK.

You must include all income and asset documentation with this application.

You must include mortgage pre-approval with this application.

You must include all *applicable* forms from Section 3 with this application.

For Questions call (617) 782-6900 and leave a message.



# **Section 1**

## **The Program Application**

# Program Application

Name \_\_\_\_\_ Home Tel. # \_\_\_\_\_

Address \_\_\_\_\_ Work Tel. # \_\_\_\_\_

City \_\_\_\_\_ State \_\_\_\_\_ Zip \_\_\_\_\_

Email (if available) \_\_\_\_\_

**Circle all unit sizes for which you are applying.** Please note that your mortgage pre-approval must cover the sales price of the largest unit size for which you are applying.

1BR

2BR

3BR

## HOUSEHOLD MEMBERS:

List **ALL** household members who will occupy the affordable home:

Name	Date of Birth	Sex	SS#	Relationship

## HOUSEHOLD TYPE (please check one):

- 6 person household: all types
- 5 person household: all types
- 4 person household: all types
- 3 person household: 1 head-of-household plus 2 members
- 3 person household: 2 heads-of-household under criteria c (see pg. 13 of the **Information Packet**) plus member
  
- 3 person household: 2 heads-of-household plus 1 members
- 2 person household: 2 heads-of-household under criteria c (see pg. 13 of the **Info Packet**)
- 2 person household: 1 head-of-household plus one member
  
- 2 person household: 2 heads-of-household
- 1 person household: all types

## HOMEOWNERSHIP:

Has anyone listed on this application owned a home in the past 3 years or does anyone on this application currently own a home? YES NO

**If you answered NO, please move on to Preference Information on the next page.  
If you answered YES, please answer all the following questions.**

---

To qualify as an **age-qualified household**, please answer the following question about the person that has owned a home in the past 3 years or who currently owns a home:

Are they age 55 or older? YES NO

---

To qualify as a **displaced homemaker**, please answer the following questions about the person that has owned a home in the past 3 years or currently owns a home:

Are they are an adult? YES NO  
Have they owned a home only with a partner? YES NO  
While married did they not work full-time, full year in the labor force but worked primarily without remuneration to care for the home or family? YES NO  
Are they currently legally separated from a spouse? YES NO  
Has the home in question already been sold? YES NO

**If you answered NO to the last two questions you are still eligible for the lottery but you must finalize your separation and/or sell your home before you will be given an opportunity to purchase an affordable unit.** Please read the Information Packet for more details.

---

To qualify as a **single parent**, please answer the following questions:

Do you have 1 or more child of whom you have custody or joint custody, or are you pregnant? YES NO  
Did you own a home with your partner or reside in a home owned by your partner? YES NO  
Has the home in question already been sold? YES NO  
Are you unmarried or legally separated from your spouse? YES NO

**If you answered NO to the last two questions you are still eligible for the lottery but you must finalize your separation and/or sell your home before you will be given an opportunity to purchase an affordable unit.** Please read the Information Packet for more details.

## DATABASE INFORMATION

How did you find out about this affordable housing opportunity?  
(write your answer in the space provided and please be as specific as possible)

Are you or any member of your household a current resident of Berlin? YES NO

Are you or any member of your household a parent, child or sibling of a current resident of Berlin? YES NO

Are you or any member of your household an employee of the Town of Berlin (i.e. a municipal employee or an employee of the Berlin school system including the regional vocational high school)? YES NO

You are requested to complete the following optional section in order to assist in determining preference. Completing this section may qualify you for additional lottery pools. (Please check all the boxes that apply):

	APPLICANT	CO-APPLICANT	DEPENDENT
<b>Black</b>			
<b>Hispanic</b>			
<b>Cape Verdean</b>			
<b>Asian/Pacific Islander</b>			
<b>Eskimo/Aleut</b>			
<b>Native American</b>			
<b>White/Non-Minority</b>			

### Instructions for Completing the Following Income Table

- In Section 3 of this application, you will be asked multiple questions about your information in the following Income and Asset tables.
- List ALL CURRENT sources of income as requested below for ALL household members over 18 years old.
- Please note that the Income Table is 2 pages and **income from Social Security, Pension, interest etc. is all on the second page of the table.**
- If you have left a job since January 1, 2010 and are no longer receiving income, do NOT list it in this table.
- For self-employed applicants- include the employer, contract or job name in the space provided.
- For periodic payments (like Social Security and child support) please include the amount received per week or per month (*ex: \$100/mo*) in the space provided under "Source of Income". Then provide the appropriate amount under "Current GROSS Monthly Income" (*ex: \$1,200*).
- "Interest Income" refers to any amount that you receive from any asset including amounts that you may be drawing down from a retirement account or 401K.
- You must provide Net Cash Value of all Retirement Accounts.
- **For any section that doesn't apply, cross out or write NA.**

## INCOME

Household Member Name	Source of Income	Current GROSS Monthly Income
	Employer (name)	
	Employer (name)	
	Employer (name)	
	Employer (name)	
	Employer (name)	
	Employer (name)	
	Employer (name)	
	Employer (name)	
	Employer (name)	
	Employer (name)	
	Self-Employed (source name)	
	Self-Employed (source name)	
	Self-Employed (source name)	
	Self-Employed (source name)	
	Child Support/Alimony	
	Child Support/Alimony	
	Periodic payments from family/friends	
	Periodic payments from family/friends	
	Other Income (name/source) <b>(ex: Down Payment Assistance)</b>	
	Other Income (name/source) <b>(ex: Down Payment Assistance)</b>	

Household Member Name	Source of Income	Current GROSS Monthly Income
	Social Security	
	Social Security	
	Social Security	
	Social Security	
	SSDI	
	SSDI	
	Unemployment Compensation	
	Workman's Compensation	
	Severance Pay	
	Pension (list source)	
	Pension (list source)	
	Retirement Funds	
	Title IV/TANF	
	Full-Time Student Income (18 & Over Only)	
	Full-Time Student Income (18 & Over Only)	
	Interest Income (source)	
	Interest Income (source)	
	Interest Income (source)	
	Interest Income (source)	
	Interest Income (source)	
	Interest Income (source)	
	Interest Income (source)	
	Total Gross Monthly Household Income (TGMHI)	\$ /month
TGMHI x 12 =	Anticipated Gross Yearly Household Income	\$ /year

ANTICIPATED CHANGES IN INCOME (please check one)	YES	NO
<p>1. Is your Anticipated Gross Yearly Household Income (written in the last box at the end of the above Income Table) <b><i>greater than the Allowable Income Limits</i></b> for a household of your size as specified on the cover page of this Program Application?</p> <p>If <b>YES</b>, please explain why you think your household is still eligible for entrance into this Lottery (<i>ex: upcoming maternity leave, planned change in employment etc.</i>):</p> <p><i>All claims made above must be supported with documentation submitted with this application.</i></p>		
<p>2. Are there any planned changes in income over the next 12 months?</p> <p>If <b>YES</b>, please explain:</p> <p><i>All claims made above must be supported with documentation submitted with this application.</i></p>		

## ASSETS

If a section doesn't apply, cross out or write NA. You will need to submit detailed bank/balance statements for EVERY ASSET listed here.

Checking Accounts	Name on Account	Bank	Amount	
				Balance \$
			Balance \$	
			Balance \$	
			Balance \$	
Savings Accounts			Balance \$	
			Balance \$	
			Balance \$	
Trust Account			Balance \$	
Certificates (or CDs)			Balance \$	
			Balance \$	
			Balance \$	
			Balance \$	
Savings Bonds	Maturity Date:		Value \$	
	Maturity Date:		Value \$	
401k, IRA, Retirement Accounts (Net Cash Value)	Company Name:		Value \$	
	Company Name:		Value \$	
	Company Name:		Value \$	
	Company Name:		Value \$	
Mutual Funds	Name:	# of Shares:	Interest/Dividends	Value
			\$	\$
			\$	\$
			\$	\$
Stocks			\$	\$
			\$	\$
			\$	\$
Bonds			\$	\$
			\$	\$
Investment Property			Appraised Value \$	

## REAL ESTATE

*You may only currently own a home if one of your household members is over the age of 55 or if you qualify as a displaced homemaker or single parent. Please read the Info Packet for more details.*

Do you currently own a home?	<input type="checkbox"/> Yes	<input type="checkbox"/> No
Location of property:	\$	
Appraised Market Value:	\$	
Mortgage or outstanding loans balance due:	\$	

# Section 2

## The Required Forms and Documentation Worksheet

Please answer each of the following 14 questions, attach all requested documentation, complete all applicable forms, and check all applicable boxes.

**Every time you answer “YES”, you MUST submit the requested documentation.**

**If you have not filed your 2009 taxes, you must ALSO provide all tax documentation from 2008 (1040s, 1099s, W-2s etc.)**

Only send copies of income/asset documentation.  
We do not want originals.

## Current Employment Questions

1. Is anyone in your household currently employed?  
(NOT including self-employment)

How many of the jobs on page 6 of the Program Application are currently being worked? (NOT including self-employment)

For **every** job listed here you need attach BOTH:

- a) Copies of the 5 most recent pay-stubs  
*(If you do not receive pay-stubs you will need to attach a note from the employer on company letterhead stating your tenure and Year To Date amount)*
- b) Attach copies of your 2009 W-2s  
*(if a job was started after January 1, 2010, write NA)*

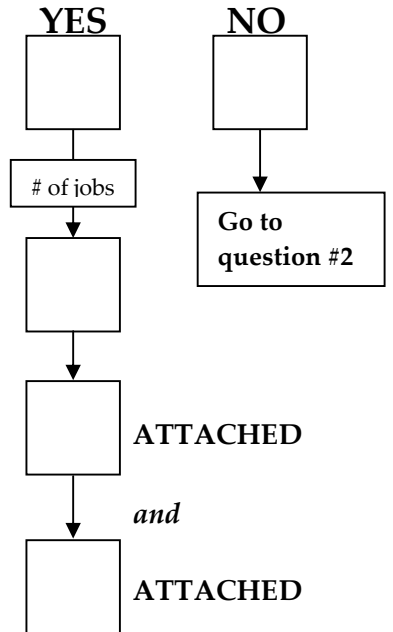

Example of a pay-stub:

Employee Name		SS#	Period End	Check Date	Check No.	Check Amount	
Bbbbbbb.Bbbbbbb B		111-66-7777	10/23/99	11/03/99	208	*****515.40	
Description	Hours	Rate of Pay	Earnings	Deductions	Current	Y-T-D	Leave Balance
Reg Pay	6.00	13.65	81.90	Fed Tax	66.39	1,530.67	
Vacation	28.00	13.65	382.20	FICA SS	40.32	985.59	VACATION 41.24
Ben Bank	1.00	90.08	90.08	FICA Med	9.43	230.50	
Misc	7.00	13.65	95.55	PA ST TX	18.19	445.06	
				Swat Tax	.00	10.00	
Description	Current	Y-T-D					
GROSS PAY	649.73	15,895.44					
TOTAL DEDUCTIONS	134.33						
NET PAY	515.40						

SWARTHMORE COLLEGE - Swarthmore, PA. 19081

Example of a blank W-2 (these are provided by your employer for your taxes):

a Control number		22222	For Official Use Only ▶ OMB No. 1545-0008	
b Employer identification number (EIN)		1 Wages, tips, other compensation		2 Federal income tax withheld
c Employer's name, address, and ZIP code		3 Social security wages	4 Social security tax withheld	
		5 Medicare wages and tips	6 Medicare tax withheld	
		7 Social security tips	8 Allocated tips	
d Employer's social security number		9 Advance EIC payment	10 Dependent care benefits	
e Employer's first name and initial		11 Nonqualified plans		12a See instructions for box 12
Last name		13a Stray income		13b
Suff.		13b Reserve pay		13c
		13c Third-party activity		13d
		14 Other		13e
f Employer's address and ZIP code				13f
15 State	Employer's state ID number	16 State wages, tips, etc.	17 State income tax	18 Local wages, tips, etc.
				19 Local income tax
				20 Locally name

Form **W-2** Wage and Tax Statement **2006** Department of the Treasury—Internal Revenue Service  
Copy A For Social Security Administration — Send this entire page with Form W-3 to the Social Security Administration; photocopies are not acceptable. Cat. No. 10134D

Do Not Cut, Fold, or Staple Forms on This Page — Do Not Cut, Fold, or Staple Forms on This Page

## Income Questions

2. Did you list any sources of Income on page 7 of this application?  
*(ie: Social Security, SSDI, Pensions, Unemployment, Public Assistance, TANF, Veteran's Benefits, Retirement, Student Income, Interest Income etc.)*

YES

NO



# of sources

How many sources of Income did you list on page 7?

Go to question #3

For **every** source of income listed, regardless of the amount of income received (even just \$1), you need to:

- Attach copies of your most recent statements from the source of income.
- Attach copies of your most recent 1099s from the source of income *(if received)*.

***If you do not receive statements*** (i.e. the amounts are direct deposited), please submit 3 months checking account statements and highlight the appropriate deposits.

ATTACHED

*Example of a blank 1099:*

9595		<input type="checkbox"/> VOID <input type="checkbox"/> CORRECTED		OMB No. 1545-0115	
PAYER'S name, street address, city, state, ZIP code, and telephone no.		1 Rents	\$	2006	Miscellaneous Income
		2 Royalties	\$	Form 1099-MISC	
		3 Other income	\$	4 Federal income tax withheld	Copy A
PAYER'S federal identification number	RECIPIENT'S identification number	5 Fishing boat proceeds	\$	6 Medical and health care payments	For Internal Revenue Service Center
RECIPIENT'S name		7 Nonemployee compensation	\$	8 Substitute payments in lieu of dividends or interest	File with Form 1098.
Street address (including apt. no.)		9 Payer made direct sales of \$5,000 or more of consumer products to a buyer (recipient) for resale <input type="checkbox"/>	\$	10 Crop insurance proceeds	For Privacy Act and Paperwork Reduction Act Notice, see the 2006 General Instructions for Forms 1099, 1098, 5498, and W-2G.
City, state, and ZIP code		11	\$	12	
Account number (see instructions)	2nd TIN not <input type="checkbox"/>	13 Excess golden parachute payments	\$	14 Gross proceeds paid to an attorney	
15a Section 409A deferrals	15b Section 409A income	16 State tax withheld	\$	17 State/Payer's state no.	18 State income
\$	\$	\$	\$	\$	\$

Form 1099-MISC 41-0852411 Department of the Treasury - Internal Revenue Service  
 Do Not Cut or Separate Forms on This Page — Do Not Cut or Separate Forms on This Page

### Past Employment Questions

- 3.** Did anyone in your household leave a job between **January 1, 2009 and today's date?**

For **each** job listed here, regardless of the amount of income received, you need to attach **one** of the following:

- a) Attach a letter from the employer on company letterhead Verifying your last day of employment.

OR

- b) Attach a copy of the last pay-stub from 2009 along with the matching 2009 W-2. The YTD amount on the pay-stub must match the wages shown on the W-2. (*Only valid for jobs left before December 1<sup>st</sup>, 2009*)

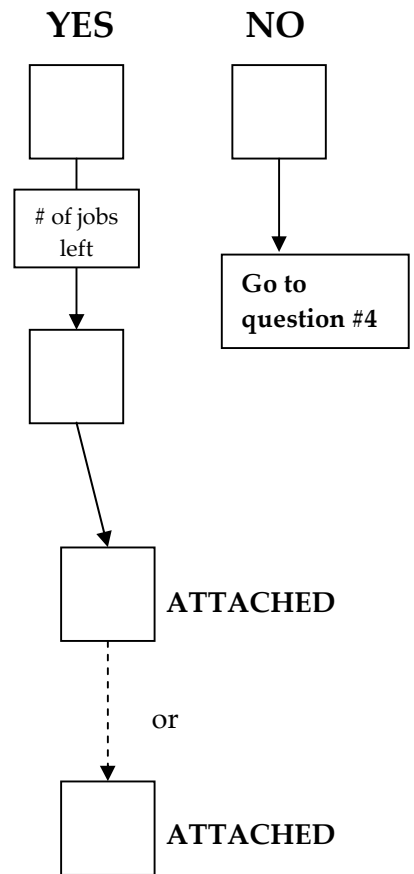

## Self-Employment Questions

- 4.** Is anyone in your household currently self-employed?

How many household members are self-employed?

For each self-employed job, complete the attached "Self-Employment Income Affidavit" in Section 3 in the back of this application. Be sure to include (all that apply):

- a) Copies of all most recent 1099s (should be 2009)
- b) A Copy of Schedule C for your most recent 1040s (should be 2009)
- c) Copies of current financial statements,
- d) Accountant's statements of Net Business Income
- e) Copies of income receipts
- f) Any other documentation you can provide to corroborate income.

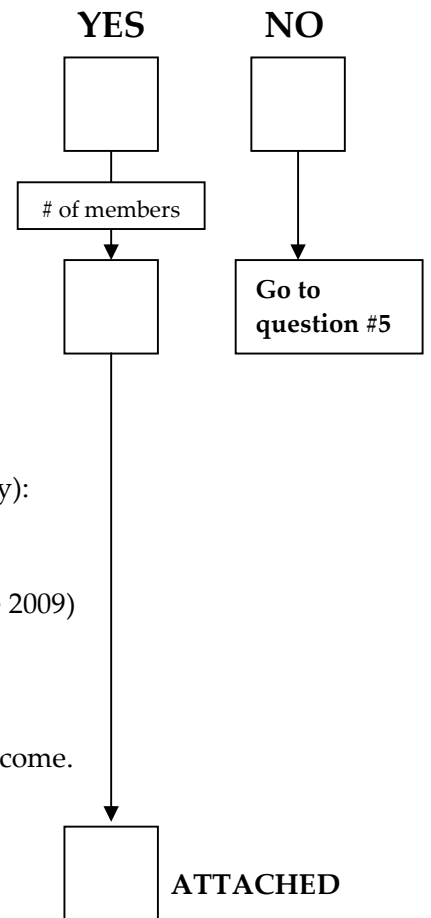

## Household Members with No Income

- 5.** Are there any household member over 18 years old that are claiming to currently make zero income?

How many household members over 18 years old are claiming to currently make zero income?

For each one of these household members, complete the "Certification of Zero Income" form attached in Section 3 in the back of this application.

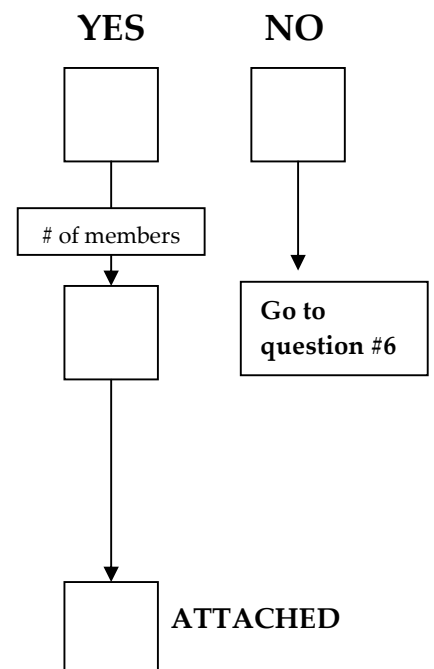

## Child Support/Alimony Questions

- 6.** Are you currently receiving child support or alimony  
OR are you *legally* entitled to receive child support  
or alimony?

If you answered YES *and* you are receiving the amount you are  
entitled to receive, you will need to attach **one** of the following:

- a) A copy of your divorce decree or settlement agreement

OR

- b) A statement of payments from the Department of Revenue (DOR)  
(*if they have your payments on record*)

OR

- c) 3 detailed checking account statements that show  
Child Support/Alimony deposits

If you answered YES *but* you are NOT receiving the amount  
you are entitled to receive, you will need to attach:

- d) A copy of your divorce decree, proof of a legal claim filed against  
the person that owes you money and, if applicable, statements  
from the DOR showing payments made  
(*If you do not show proof of a legal claim, it will be assumed you are  
receiving the full amount entitled when determining your eligibility*)

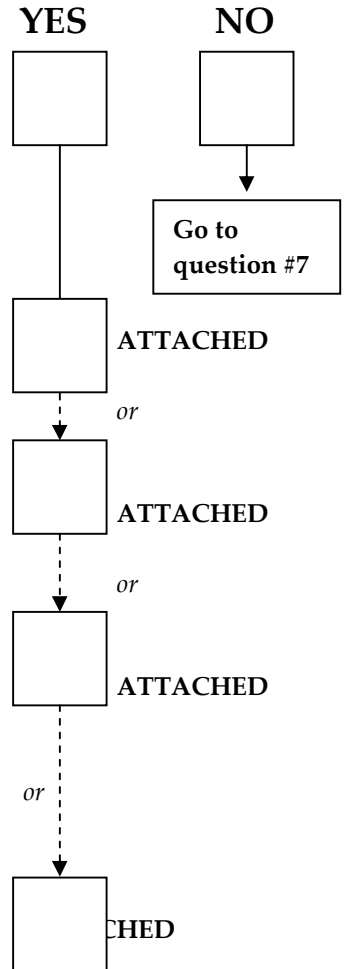

## Divorce/Separation Questions

- 7.** Have you been divorced/separated since January 1<sup>st</sup>, 2008 or  
are you currently in the process of getting divorced/separated?

If you answered YES, you will need to attach:

- a) Proof that you have filed for divorce/separation  
(*Your divorce needs to be finalized to apply for an affordable home.*)

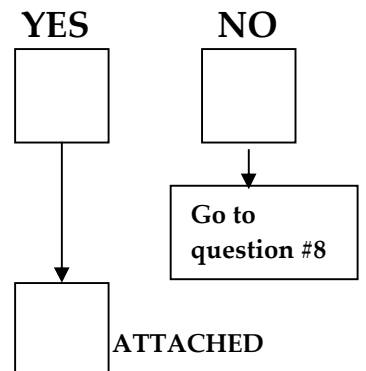

*If you have only filed for divorce or separation at this point, please note that your application will be accepted but you will not be able to purchase a home until your divorce/separation is finalized. You should take all possible steps to expedite a hearing. If you have not taken any legal action in filing for divorce or separation, you cannot apply as a single head-of-household. Your partner's income and assets will need to be included in your application.*

## Periodic Payment Questions

8. Did you list any sources under "Periodic Payments" on page 6? (i.e. payments from family members or recurring gifts)

How many sources did you list?

Please have your Contributor complete the "Recurring Gifts and Contributions Verification" form in Section 3 of this application. You can either attach the completed form with this application or have your Contributor mail it in.

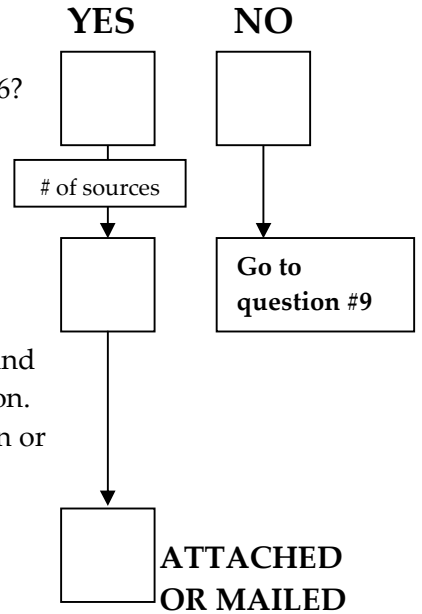

## "Other Income" or Down Payment Assistance Questions

9. Did you list any sources under "Other Income" on page 6 of Section 1? **Any money a friend, family member or other source may use in helping you with your down payment or future housing costs must be noted here but will count towards your assets.**

How many sources did you list?

Please provide all necessary information to verify this source of Income and describe the source here:

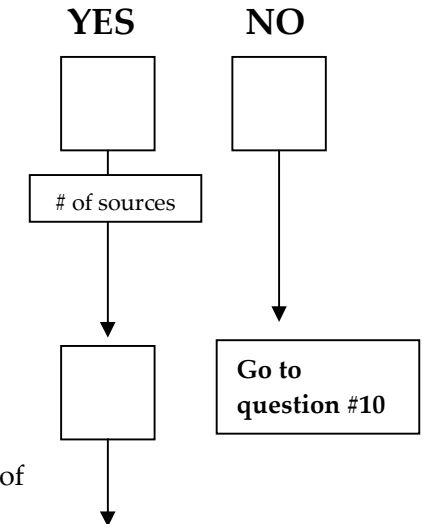

## Asset Questions

- 10.** How many different Assets did you list on page 9?  
 (This includes Checking Accounts, Savings Accounts, Stocks, Bonds,  
**Net Cash Value of Retirement Accounts** etc.)

For **every** asset listed, REGARDLESS of the amount of money in the account (even just \$1), you need to:

- Attach copies of any of your most recent statements from the source of income (for checking accounts, attach **3** detailed statements)
- Attach any copies of 2009 1099s or end-of-year statements you may have received from the asset source.

# of Assets

 ATTACHED

## Real Estate Questions

*(Current Homeownership is only allowed for Age-Qualified Households, Displaced Homemakers and Single Parents)*

- 11.** Do you currently own a home or property?

YES

NO



# of properties

How many different properties/homes do you currently own?

Go to question #13

For every property you need to submit **all** of the following:

- Attach a copy of the Purchase and Sale Agreement for the upcoming sale of your home
- Attach a statement from your lender showing your current balance on your mortgage or outstanding loans

 ATTACHED

*Please note, you will not be able to purchase a new affordable home until your current home is sold or under a P&S Agreement with another buyer (see the Information Packet).*

## Households with Students

- 12.** Are any household members over 18 years old currently students or have been students in the past 12 months?

How many?

For each student you need to attach **School Transcripts** for the past 12 months.

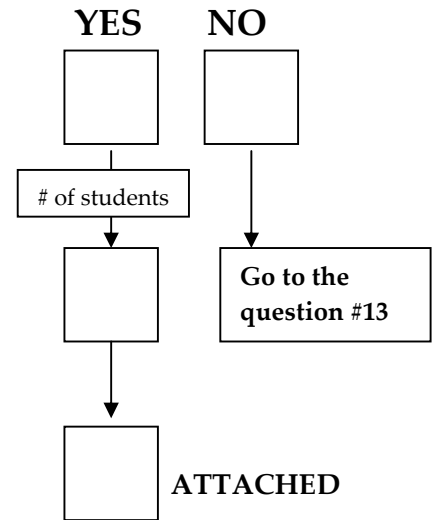

### 3 most recent 1040 Tax Transcripts (2007, 2008 & 2009)

# of members

## 13. How many members are in your Household?

EVERY one of your household members should be listed on a 1040 Tax Transcript for 2007, 2008 AND 2009 (unless they were not yet born). You need to submit all these 1040 Tax Transcripts from the past 3 years. If you have not yet filed your 2009 taxes you will need to send in your **2006 1040s**. SEND IN EVERY PAGE!!!

**Do NOT send in a copy filled out by hand.** If you had a professional prepare your taxes, they will have the transcripts you need. You can also call the IRS at (800) 829-1040 and they can mail or fax you a copy of any of these transcripts.

For each household member that has not filed Taxes nor been on a Tax Transcript for any of the last 3 years, you must submit a Statement from the IRS showing "NO RECORD" of filing (unless they were not yet born). Please call (800) 829-1040 to request a statement. Only if a member has not filed for approx. 5+ years, will the IRS not be able to provide a statement.

If a household member moved to this country in the past 3 years and does not have 3 years of tax transcripts, you need to also submit proof of his date of immigration.

**ALL 1040s ATTACHED**

*Example of a blank 1040. The 1040s you send in must be complete and computer generated. Do not send in the form you filled out by hand!*

Form 1040		Department of the Treasury—Internal Revenue Service		2005		OMB No. 1545-0074	
U.S. Individual Income Tax Return							
For the year Jan. 1-Dec. 31, 2005, or other tax year beginning _____, 2005, ending _____, 20		Your first name and initial _____		Last name _____		Your social security number _____	
If a joint return, spouse's first name and initial _____		Last name _____		Spouse's social security number _____		You must enter your SSN(s) above	
Home address (number and street). If you have a P.O. box, see page 10. _____		Apt. no. _____		City, town or post office, state, and ZIP code. If you have a foreign address, see page 10. _____		Checking a box below will not change your tax or refund.	
Presidential Election Campaign: <input type="checkbox"/> Yes <input type="checkbox"/> No		Check here if you, or your spouse if filing jointly, want \$3 to go to this fund (see page 15). <input type="checkbox"/> Yes <input type="checkbox"/> No		Spouse checked on 8a and 8b		No. of children	
Filing Status		<input type="checkbox"/> Single <input type="checkbox"/> Married filing jointly (even if only one had income) <input type="checkbox"/> Married filing separately. Enter spouse's SSN above and full name here. <input type="checkbox"/>		<input type="checkbox"/> Head of household (with qualifying person). (See page 17.) If the qualifying person is a child but not your dependent, enter this child's name here. <input type="checkbox"/> <input type="checkbox"/> Qualifying widow(er) with dependent child (see page 17)		<input type="checkbox"/> Spouse checked on 8c who:	
Exemptions		<input type="checkbox"/> Yourself. If someone can claim you as a dependent, do not check box 8a. <input type="checkbox"/> Spouse		(1) Dependents: (i) First name Last name (ii) Dependents' social security number (iii) Dependents' relationship to you (iv) If filing all to child (see page 17)		<input type="checkbox"/> Head with you <input type="checkbox"/> did not live with you due to choice of separation (see page 21) Dependents on 8c not entered above	
Income		7 Wages, salaries, tips, etc. Attach Form(s) W-2		7		8a	
8a Taxable interest. Attach Schedule B if required		8a		8b		8a	
8b Tax-exempt interest. Do not include on line 8a		8b		8c		8a	
8c Ordinary dividends. Attach Schedule B if required		8c		8d		8a	
8d Qualified dividends (see page 23)		8d		8e		8a	
10 Taxable refunds, credits, or offsets of state and local income taxes (see page 29)		10		11		8a	
11 Alimony received		11		12		8a	
12 Business income or (loss). Attach Schedule C or C-EZ		12		13		8a	
13 Capital gain or (loss). Attach Schedule D if required. If not required, check here <input type="checkbox"/>		13		14		8a	
14 Other gains or (losses). Attach Form 4797		14		15a		8a	
15a IRA distributions		15a		15b		8a	
15b Pensions and annuities		15b		16a		8a	
16a Rental real estate, royalties, partnerships, S corporations, trusts, etc. Attach Schedule E		16a		16b		8a	
16b Farm income or (loss). Attach Schedule F		16b		17		8a	
17 Unemployment compensation		17		18		8a	
18 Social security benefits		18		19		8a	
19 Other income. List type and amount (see page 29)		19		20a		8a	
20a Add the amounts in the far right column for lines 7 through 21. This is your total income		20a		21		8a	
21 Adjusted Gross Income		21		22		8a	
22 Add the amounts in the far right column for lines 23 through 37. This is your adjusted gross income		22		23		8a	
23 Educator expenses (see page 29)		23		24		8a	
24 Certain business expenses of reservists, performing artists, and fee-basis government officials. Attach Form 2106 or 2106-EZ		24		25		8a	
25 Health savings account deduction. Attach Form 8889		25		26		8a	
26 Moving expenses. Attach Form 3903		26		27		8a	
27 One-half of self-employment tax. Attach Schedule SE		27		28		8a	
28 Self-employed SEP, SIMPLE, and qualified plans		28		29		8a	
29 Self-employed health insurance deduction (see page 30)		29		30		8a	
30 Penalty on early withdrawal of savings		30		31a		8a	
31a Alimony paid b Recipient's SSN <input type="checkbox"/>		31a		32		8a	
32 IRA deduction (see page 31)		32		33		8a	
33 Student loan interest deduction (see page 33)		33		34		8a	
34 Tuition and fees deduction (see page 34)		34		35		8a	
35 Domestic production activities deduction. Attach Form 8803		35		36		8a	
36 Add line 23 through 31a and 32 through 35		36		37		8a	
37 Subtract line 36 from line 22. This is your adjusted gross income		37				8a	

## Mortgage Pre-Approval

# of HOH

**14.** How many Heads-Of-Household (HOH) does your household have?

**You must submit a mortgage pre-approval that follows the following standards.**

- The loan must have a fixed interest rate through the full term of the mortgage.
- The loan must have a current fair market interest rate.  
*(No more than 2 percentage points above the current MassHousing rate\*)*
- The loan can have no more than two points.
- The buyer must provide a down payment of at least 3% - half of which must come from the buyer's own funds.

\*MassHousing: (617) 854-1000 or [www.masshousing.com](http://www.masshousing.com)

**If you are applying for a 1BR unit, make sure your mortgage pre-approval is for at least \$138,000.**

**If you are applying for a 2BR unit, make sure your mortgage pre-approval is for at least \$154,470.**

**If you are applying for a 3BR unit, make sure your mortgage pre-approval is for at least \$173,000.**

The following lenders are familiar with the process and the mortgage requirements and should be happy to help you with questions or pre-approvals:

- Jeff Perkins and Katie Flaherty from Clinton Savings Bank in Berlin (978.365.3700)
- Donna Koulas from Bank of America (978.250.9034)
- Matt Happy from Sovereign Bank (508.421.9750)
- Carrie Carrizosa from Boston Private Bank & Trust Company (617.912.4213)
- Ron Wiltshire from Wainwright Bank (617.319.2599)
- Mark Richard from Wells Fargo (978-318-9501 ext.1002)

**PRE-APPROVAL  
ATTACHED**

**You and Your Co-Applicant  
Must Sign and Date the  
Following Page**

**Again, if you have not filed your 2009 taxes, you  
must ALSO provide all tax documentation from  
2008 (1040s, 1099s, W-2s etc.)**

The information given in this application will be used to check that you are income qualified to be given an opportunity to purchase an affordable unit in the Town of Berlin as part of this program. Acceptance of this application does not guarantee you a unit.

This development does not discriminate based on race, color, national origin, religion, sex, familial status, and handicap (disability).

THE UNDERSIGNED HEREBY CERTIFY THAT THE INFORMATION SET FORTH ABOVE IS TRUE AND CORRECT. THE UNDERSIGNED ACKNOWLEDGE THAT IF ANY OF THE INFORMATION ABOVE IS NOT TRUE AND ACCURATE THIS APPLICATION MAY BE REMOVED AT ANY POINT. THE UNDERSIGNED ACKNOWLEDGE THAT THE RESIDENCY AGREEMENT FOR THE UNIT TO BE OCCUPIED BY THE UNDERSIGNED MAY BE SUBJECT TO CANCELLATION IF ANY OF THE INFORMATION ABOVE IS NOT TRUE AND ACCURATE.

THE UNDERSIGNED GIVE CONSENT TO THE MONITORING AGENT, THE TOWN OF BERLIN AND STOCKARD ENGLER BRIGHAM, LLC TO VERIFY ALL INFORMATION PROVIDED IN THIS APPLICATION.

THE UNDERSIGNED AUTHORIZE THE RELEASE OF INFORMATION NECESSARY IN DETERMING INCOME AND ASSETS FROM THIRD-PARTY REFERENCES.

\_\_\_\_\_  
Applicant Signature

\_\_\_\_\_  
Date

\_\_\_\_\_  
Co-Applicant Signature

\_\_\_\_\_  
Date

**Send applications with ALL required documentation to:**

**SEB  
Re: Sawyer Hill  
165 Chestnut Hill Ave Unit 2  
Brighton, MA 02135**

**For Questions call (617) 782 6900 and leave a message.**

# **Section 3**

## **Additional Forms** *(if applicable)*

**These are the forms that you only need to complete  
if directed to do so in Section 2**

# Verification of Terminated Employment

---

**To Be Completed By Applicant:**

**Applicant/Tenant:** \_\_\_\_\_

**Soc. Security #:** \_\_\_\_\_

Contact Info of previous employer:

Name of Contact					
Company Name					
Street Address					
City, State, Zip					
Tel. #		Fax #		email	

---

**To Be Completed By Previous Employer:**

Date of Termination: \_\_\_\_\_ Last Day Actually Worked: \_\_\_\_\_

Total Gross Income paid to employee over the last calendar year employed: \_\_\_\_\_

Reason for Termination:     Employee Quit     Other \_\_\_\_\_

Do you anticipate rehiring this employee?     Yes     No    If yes, when: \_\_\_\_\_

Will the employee receive additional paychecks for Workman's Compensation?     Yes     No

If yes, provide the name and address of the company through which this can be verified:

\_\_\_\_\_

\_\_\_\_\_

Total severance pay anticipated for the next 12 months: \_\_\_\_\_

Is employee entitled to receive unemployment compensation?     Yes     No

### AUTHORIZED SIGNATURE

Print Name: \_\_\_\_\_ Title: \_\_\_\_\_

Signature: \_\_\_\_\_ Date: \_\_\_\_\_

Telephone: \_\_\_\_\_

Please Fax form to SEB at (617) 782-4500 or mail to:    SEB

Re: Sawyer Hill  
165 Chestnut Hill Ave Unit 2  
Brighton, MA 02135

---

**--OFFICE USE ONLY--**

Date Sent: \_\_\_\_\_

Date Received: \_\_\_\_\_

Comments: \_\_\_\_\_

# Self-Employment Income Affidavit

Anticipated Self-Employment earnings for this calendar year	\$
Previous year's Self-Employment income	\$

Please attach a current financial statement, accountant's statement of Net Business Income for this calendar year, income receipts, or any documentation you can provide to corroborate the income and earnings stated above.

Also attach a copy of last year's executed tax return including Schedule C.

## CERTIFICATION

I certify that the above listed income amounts are accurate and I have provided all of the above requested information.

Signature :	
Print Name:	
Date:	

# Certification of Zero Income

(To be completed by **adult** household members only, if appropriate)

Household Name: \_\_\_\_\_ Development Name: **Sawyer Hill EcoVillage**

1. I hereby certify that I have not received income from any of the following sources during the previous 12 months:
  - a. Wages from employment (including commissions, tips, bonuses, fees, etc.);
  - b. Income from operation of business;
  - c. Rental income from real or personal property;
  - d. Interest or dividends from assets;
  - e. Social Security payments, annuities, insurance policies, retirement funds, pensions, or death benefits;
  - f. Unemployment or disability payments;
  - g. Public assistance payments;
  - h. Periodic allowances such as alimony, child support, or gifts received from persons not living in my household;
  - i. Sales from self-employed resources (Avon, Mary Kay, Cutco, etc.);
  - j. Any other source not named above.
  
2. I will be using the following sources of funds to pay for rent and other necessities:  
\_\_\_\_\_  
\_\_\_\_\_

Under penalty of perjury, I certify that the information presented in this certification is true and accurate to the best of my knowledge. The undersigned further understand(s) that providing false representations herein constitutes an act of fraud. False, misleading or incomplete information may result in the termination of a lease agreement.

\_\_\_\_\_  
Signature of Applicant/Tenant

\_\_\_\_\_  
Printed Name of Applicant/Tenant

\_\_\_\_\_  
Date

# Recurring Gifts and Contributions Verification

---

**To Be Completed By Applicant:**

Applicant/Tenant: \_\_\_\_\_  
Soc. Security #: \_\_\_\_\_  
Property Name: Sawyer Hill EcoVillage  
Address: Not Yet Determined  
Berlin, MA

---

**To Be Completed By Contributor:**

**Please complete the following:**

I, (Contributor's Name) \_\_\_\_\_,  
contribute \$ \_\_\_\_\_ per \_\_\_\_\_ to the above named household  
for the purpose of: \_\_\_\_\_

**Non-Monetary Contributions:**

I, (Contributor's Name) \_\_\_\_\_

Contribute any of the following on a regular basis:

Gas for the car	\$ _____	Car Payments Directly to Bank	\$ _____
Alcohol	\$ _____	Utility Payments	\$ _____
Cigarettes	\$ _____	Clothing	\$ _____
Diapers	\$ _____	Other	\$ _____
Child Care Payments	\$ _____	<b>NOTE: Food is excluded</b>	

Print Name: \_\_\_\_\_ Signature: \_\_\_\_\_  
Telephone: \_\_\_\_\_ Date: \_\_\_\_\_  
Witnessed By: \_\_\_\_\_ Date: \_\_\_\_\_  
Print Name: \_\_\_\_\_

**Include this form with the Program Application, fax it to (617) 782-4500 or have the Contributor mail it to:**

The Affordable Housing Lottery  
Re: Sawyer Hill  
165 Chestnut Hill Ave Unit 2  
Brighton, MA 02135

---

**--OFFICE USE ONLY--**

Date Sent: \_\_\_\_\_ Date Received: \_\_\_\_\_

Comments: \_\_\_\_\_